

### SL-series solid state output relay

- Plug-in output relay for AC loads, 120 VAC control
- 3 A continuous current, 90 A/20 ms
- 0...240 VAC nominal load voltage
- Small leakage current
- Works correctly from zero load upwards
- Power factor independent (0...1)
- Proximity switch compatible input
- Full wave rectification in input side
- cULus tested
- CE (EMC and LVD tested)
- Not for motor loads

### Block diagram

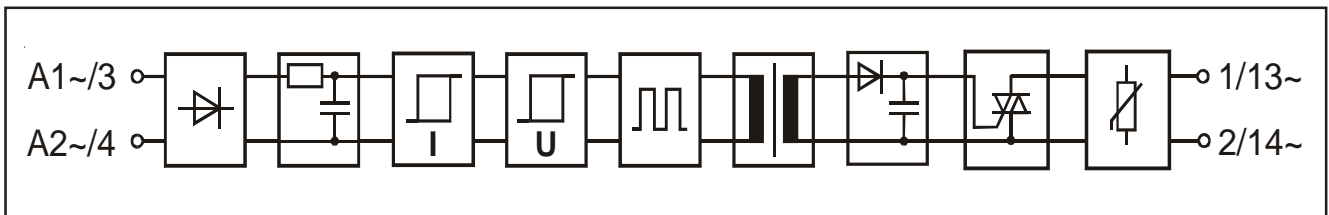

### Specifications (at temperature of 25 °C)

#### Primary

Input voltage	nominal	120 VAC
Input current at nominal voltage	typical	5 mA
	maximum	6 mA
Input voltage range (abs.)	minimum	95 VAC
	maximum	140 VAC
Input impedance	typical	24 kΩ
Switch-on voltage	typical	80 VAC
	maximum	95 VAC
Switch-off voltage	typical	65 VAC
	minimum	55 VAC
Switch-off current	typical	3 mA

#### Secondary

Load voltage	minimum	0 VAC
	nominal	240 VAC
	maximum	265 VAC
Load current (absolute)	maximum	3 A
Load current 20 ms	maximum	90 A
Voltage drop at max. load	typical	1 V
Output leakage	typical	2 mA
Switch-on delay	typical	10 ms
	maximum	-
Switch-off delay	typical	20 ms
	maximum	-
Load power factor, cos φ		0...1
dV/dt off-state	typical	200 V/μs

### Physical dimensions and other data

Breakdown voltage	minimum	4000 VAC rms
Resistance	minimum	10 <sup>10</sup> Ω
Material of casing		thermoplastic
Weight	typical	40 g
Air/creepage distance	minimum	8 mm
Capacitance I/O	typical	3 pF

Color of casing: black

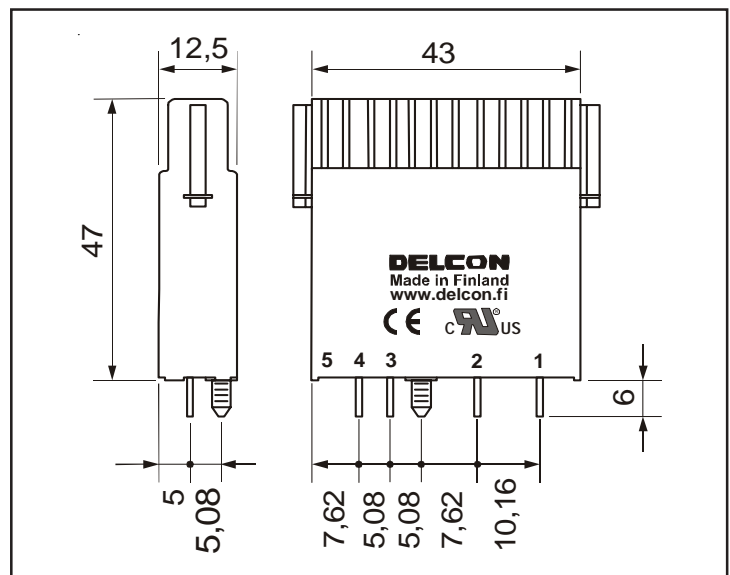

Dimensions in mm.

## Temperature derating

### Ambient temperature Limitation

-25 °C...+40 °C	Allowed maximum load current is 33 % of the curve below when assembled side by side.
+40 °C...+55 °C	Only every other relay should be in on-state at current which is 33 % of the curve below or less when assembled side by side.
+55 °C...+70 °C	If relays are even part of the time on, there should be a gap in both sides at least 12,5 mm. Notice also the curve below.

### Temperature range:

Storage:	-40 °C...+70 °C
Operation:	-25 °C...+70 °C

Derating curve for the relay when there is at least 12,5 mm gap between relays. Allowed load is derated to 1/3 linearly from +30 °C to +70 °C ambient temperature.

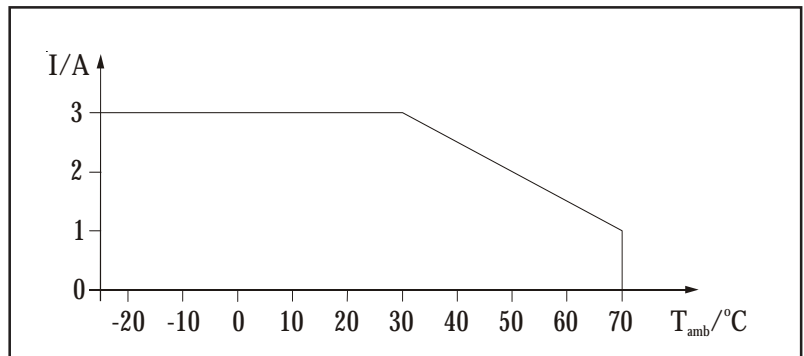

## Derating when switching inductive loads

There is no need to derate solid state output relay using a triac switch. The relay is indifferent to the power factor of the load. Calculation should be made however that the surge current does not exceed the specification. For reasons of heat dissipation, when the load will be switched frequently, the average current over a reasonable time should not exceed the specification for continuous operation.

## Fusing

To protect relay against short circuit and overload a fast fuse with the correct rating for the load and the capacity of the relay should be chosen, for instance from the Wickman 193 range. Note that when overload current is not large it is possible that the fuse will not protect the relay because of the tolerance on the fuse rating.

## Approvals



UL-file E 162828



The relay fulfils EMC-directive 89/336/EEC requirements. Product has been tested according generic standards EN50081-2 and EN50082-2. The relay fulfils also requirements of the low voltage directive 73/23/EEC.

## Guarantee

The solid state I/O relays and accessories made by Delcon Oy are guaranteed free from design and manufacturing defects for a period of three years from the shipping date. For electromechanical relays the guarantee is one year. The guarantee liability is limited to replacement of defective material and related shipping charges. Defective products must be returned to the factory for evaluation. This guarantee does not cover damage due to incorrect use or electrical overload.

**Delcon Oy**  
Veikkointie 4  
03100 Nummela  
Finland

Tel. +358 9 7771180  
Fax +358 9 77711840  
www.delcon.fi

30.12.2003