

- Plug-in input relay for 220...240 VAC voltages
- 50 mA maximum load current
- 0...60 VDC load voltage
- Works without logic supply (4 pole)
- For PLC input signal conditioning
- Internal transient protection in input side
- Shielded signal cabling not required
- cULus tested (UL and CSA)
- CE (EMC and LVD tested)
- Integrated status LED

Block diagram

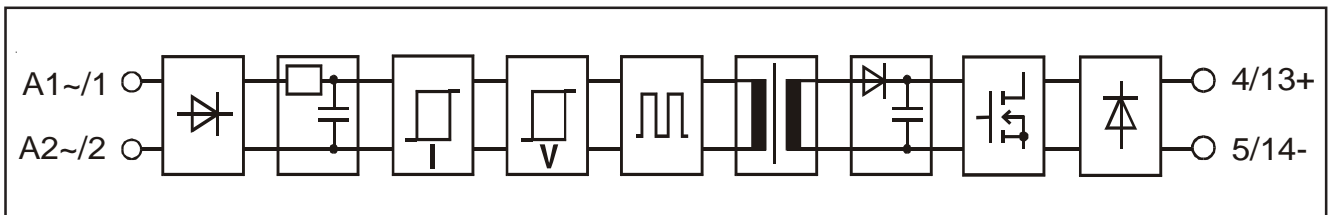

Specifications (at temperature of 25 °C)

Primary

Input voltage	nominal	220...240 VAC
Input current	typical	5 mA
at nominal voltage	maximum	6 mA
Input voltage	minimum	190 VAC
range (abs.)	maximum	265 VAC
Input impedance	typical	45 kΩ
Switch-on voltage	typical	170 VAC
	maximum	190 VAC
Switch-off voltage	typical	110 VAC
	minimum	80 VAC
Noise immunity	typical	55 mJ

Secondary

Load voltage	minimum	0 VDC
	maximum	60 VDC
Load current	maximum	50 mA
Voltage drop at max. load	typical	0,2 V
	maximum	0,4 V
Switch-on delay	typical	50 ms
	maximum	-
Switch-off delay	typical	50 ms
	maximum	-

Physical dimensions and other data

Breakdown voltage	minimum	4000 VAC rms
Resistance	minimum	10 ¹⁰ Ω
Material of casing	thermoplastic	UL 94 V-0
Weight	typical	40 g
Air/creepage distance	minimum	8 mm
Capacitance I/O	typical	3 pF

Color of casing: yellow

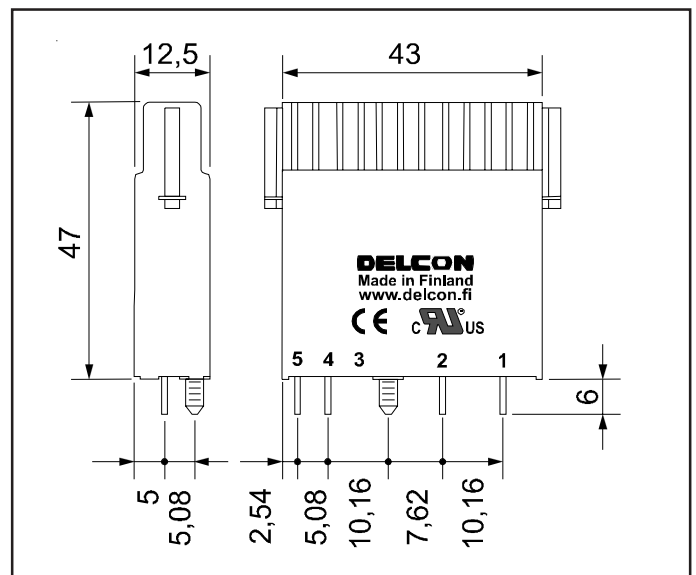

Dimensions in mm.

Temperature limitations

Ambient temperature

Limitation

-25 °C...+40 °C

No limitations

+40 °C...+55 °C

Only every other relay should be in on-state when assembled side by side.

+55 °C...+70 °C

If relays are most of the time on, there should be a gap in both sides at least 12,5 mm. In multichannel mounting bases every other place should be empty.

Temperature range:

Storage: -40 °C...+70 °C

Operation: -25 °C...+70 °C

Derating when switching inductive loads

This relay is ment for PLC inputs and similar loads. A clamp diode must be used when swiching inductive loads.

Fusing

To protect relay against short circuit and overload a fast fuse with the correct rating for the load and the capacity of the relay should be chosen, for instance from the Wickman 193 range. Note that when overload current is not large it is possible that the fuse will not protect the relay because of the tolerance on the fuse rating.

Approvals



UL-file E 162828



The relay fulfils EMC-directive 89/336/EEC requirements. Product has been tested according generic standards EN50081-2 and EN50082-2. The relay fulfils also requirements of the low voltage directive 73/23/EEC.

Guarantee

The solid state I/O relays and accessories made by Delcon Oy are guaranteed free from design and manufacturing defects for a period of three years from the shipping date. For electromechanical relays the guarantee is one year. The guarantee liability is limited to replacement of defective material and related shipping charges. Defective products must be returned to the factory for evaluation. This guarantee does not cover damage due to incorrect use or electrical overload.

Delcon Oy
Veikkointie 4
03100 Nummela
Finland

Tel. +358 9 7771180
Fax +358 9 77711840
www.delcon.fi

9.8.2004